

# Benchmarking Quasi-Steady State Cascading Outage Analysis Methodologies

Emanuele Ciapessoni, Diego Cirio, Eduardo Cotilla-Sanchez, Ruisheng Diao, Ian Dobson, Anish Gaikwad, Pierre Henneaux, Stephen Miller, Milorad Papic, Andrea Pitto, Junjian Qi, Nader Samaan, Giovanni Sansavini, Sunitha Uppalapati, Rui Yao

**Abstract**—Various methodologies exist for assessing the risk of cascading outage in power systems, differing in the cascading mechanisms considered and in the way they are modeled. These methodologies can be classified in three groups: static computation (QSS methodologies), dynamic computation (dynamic methodologies), or a combination of both (hybrid methodologies). The objective of this paper is to benchmark the performance of several widely used QSS cascading outage methodologies. For that purpose, they are applied on a unique system, the RTS-96, and the results are compared. Several metrics and indicators are used for that comparison: expected demand loss, distribution of demand loss, distribution of lines outaged and critical lines. Results show common trends but also discrepancies between methodologies. It implies that there is not yet a standardized way to analyze the risk of cascading outage in power systems, and that the specific tool used by a power system engineer can impact the recommendations.

**Index Terms**—Cascading outage, Blackout, Power system security, Power system reliability, Risk analysis

## I. INTRODUCTION

Various methodologies exist for assessing the risk of cascading outage in power systems. These methodologies differ in the cascading mechanisms considered and in their modelling. The use of a specific methodology for the planning and the operation of a power system is relevant only if the results of that methodology can be trusted, i.e. only if they approximate reality with some degree of fidelity. There are mainly two ways to analyze the performances of a specific methodology: to compare it to other methodologies, i.e. to benchmark it, and to compare it to real measured or historical data, i.e. to validate it. The objective of this paper is to benchmark the performance of several widely used Quasi-Steady-State (QSS) cascading outage methodologies.

Benchmarking and validation of cascading failure analysis tools are extensively discussed in [1]. In particular, that paper proposed a general definition of benchmarking: “Benchmarking is a process for measuring the performance of a tool, such as a software program or a business process, using a trusted procedure and/or dataset, in a way that allows one to compare the performance of one tool to another.” In this paper, the concept of benchmarking of cascading outage methodologies is implemented as the process of comparing the results of one cascading outage methodology to another using a standardized dataset. It is important to stress that such a benchmarking

leads only to relative comparisons between methodologies and cannot lead to conclusions about the relevance (or the absolute performance) of a specific methodology. That is, we cannot give a definitive validation since there is no historical data for the chosen test system. However, we can give a sample of historical data to display the general form of real-world results that can help guide the art and science of cascading simulations as they progress.

In order to benchmark several widely used QSS cascading outage methodologies, this paper is organized as follows. Section II presents the common features and the differences of the benchmarked methodologies. Section III introduces a set of indicators to benchmark the methodologies. Section IV presents the results derived from the application of the methodologies to a common test system. Section V discusses the practical implications of the benchmarking exercise. Finally, section VI concludes.

## II. METHODOLOGIES

The methodologies for cascading outage analysis can be classified according to the computation of the electrical variables after each cascading event: static computation (QSS methodologies), dynamic computation (dynamic methodologies), or a combination of both (hybrid methodologies). This paper focuses on QSS cascading outage methodologies. There are many of them, each one having its own specificity. Nevertheless, the methodologies follow a common canvas and the specific features can be classified according to several dimensions.

As shown in Figure 1, the typical canvas can be summarized as follows. The system is initialized at the pre-contingency state, and one or several initial contingencies are triggered, i.e. the initiating event(s). Then, the post-contingency state is computed. If one or several elements are enduring unacceptable working conditions (e.g. flow or voltage violations), they can be disconnected. If one or several elements are disconnected, the process of the post-contingency state computation is repeated, until no new significant violation/disconnection occurs. Final consequences are recorded and the analysis is repeated for other conditions.

Specific features of each methodologies within this typical canvas are portrayed as several dimensions. A first dimension differentiating approaches is the scope of the analysis in terms of the analyzed pre-contingency states. Most methodologies aim at estimating the risk of cascading outage for a specific

Work prepared by the IEEE Working Group on Understanding, Prediction, Mitigation and Restoration of Cascading Failures

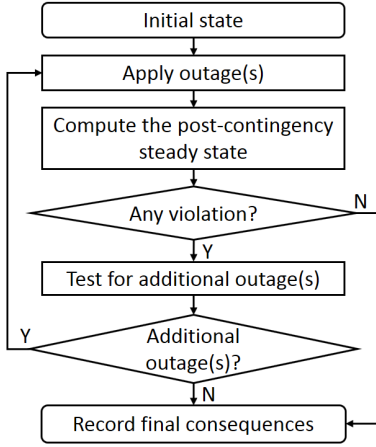

Fig. 1. Typical canvas of QSS cascading outage methodologies

operating state, but some methodologies aim at estimating the risk of cascading outage for an extended time frame, i.e. one year, by assuming an overarching operating strategy. A methodology aiming at estimating the risk of cascading outage for a specific state can be used also to estimate the risk within a time frame by performing the analysis for all conditions that could arise during that time frame. Furthermore, methodologies aiming at estimating the risk of cascading outage for an overall year can be used to estimate the risk for a specific state, by enforcing the consideration of that state only.

A second dimension is the degree of stochasticity, for both the initiating events and the subsequent events. When a purely deterministic approach is used for the selection of the initiating events, their likelihood is not considered by the methodology, and the  $N-k$  events with a same  $k$  are considered comparable. On the contrary, when a probabilistic approach is used for the initiating events, their likelihood (i.e., frequency or probability of occurrence) is explicitly considered. Note however that a probability can be nevertheless associated *a posteriori* to initiating events for deterministic approaches in a post-processing phase. When a purely deterministic approach is used for the cascading events, cascading outages are simulated only on the basis of thresholds, i.e. an element is disconnected if a corresponding threshold is violated. In that case, one particular initiating event leads to a unique cascading scenario for a specific operating state. Conversely, when a probabilistic approach is used for initiating events, cascading events are not triggered automatically upon a violation of an electrical variable (e.g., load on a line, voltage at a bus), but they have a probability to appear that depends on the value of the electrical variable exceeding the safety margins.

A third dimension is the population of the contingency list. These may be listed according to systematic enumeration, i.e. the list of initiating events is build systematically to include  $N-k$  events, or to Monte Carlo simulation, i.e., the list of initiating events is sampled. Some methods include a reduction step of the number of contingencies so that only those likely to be most critical are tested in the cascading phase.

A fourth dimension is the Power Flow (PF) model used.

The representation of the transmission system can be based on the full version of power flow equations (i.e., AC PF), or on the linearized version (i.e., DC PF). The computation of the steady state following a topology change can be based on a direct solution of the power flow equations, or on an optimal power flow (OPF), which capture the deployment of manual control actions. In case of a load/generation imbalance following a system split or the loss of a generating unit, a simplified model of the primary frequency control is used to simulate the restoration of the load/generation balance. Some models include corrective actions implementing automatic (i.e. automatic defense schemes) or manual load shedding, which are activated in case of lack of power flow convergence. Conversely, other models assume a global voltage instability in case of lack of power flow convergence. A fifth dimension is spanned by the cascading mechanisms. Cascading due to overloaded branches (e.g., overloaded lines) is a mechanism considered by all methodologies. The tripping of overloaded elements can represent a “thermal failure” (e.g., tree flashover for an overhead line), or the activation of a protection systems (e.g., overcurrent protections). The incorrect operation of protection systems such as hidden failures is not modeled systematically by QSS methodologies, but is considered in several of them. When the AC power flow equations are used, the disconnection of loads and/or generators in case of unacceptable voltage conditions are also implemented as a cascading mechanism in some of the tools. Uncertainty in the protections settings can be also represented. Finally, although QSS methodologies do not consider the full dynamics of power systems, several dynamic cascading phenomena (e.g., frequency instability, transient instability, voltage instability) are represented in a simplified way or by heuristics in some methodologies.

Table I classifies the QSS cascading outage methodologies benchmarked in this paper according to the different dimensions. Commercial methodologies usually have a limited degree of explicit stochasticity, while research-grade methodologies tend to represent uncertainties more explicitly (i.e., probabilistic approaches for both the initiating and the cascading events).

The discrepancies between methodologies lead to different requirements on the data needed to estimate the risk of cascading outages. The OPA methodology requires data on the transmission system (i.e., impedances of transmission elements), data on load (peak load and load duration curve) and data on generating units (maximum output power, unit costs). However, it does not require power flow data of a specific operating state like other methodologies do. The OPA methodology calculates a long-term risk accounting for a slow system upgrade, whereas the other methodologies calculate the risk of a fixed power system. The load duration curve and the unit costs are not needed when the risk of cascading outage is analyzed for a specific operating state. The degree of stochasticity embedded in the method strongly influences the need of probabilistic data. Purely deterministic methodologies do not need probabilistic data. In probabilistic methods, the likelihood of initiating events is estimated via reliability data

TABLE I  
CLASSIFICATION OF QSS CASCADING OUTAGE METHODOLOGIES

Name	Ref.	Type	Consideration of initiating events	Selection of the ulterior events	Contingency list	Operating state	PF model	Cascading mechanisms
Manchester	[2]	R&D	Probabilistic	Probabilistic	Monte Carlo	Specific state needed	AC	OL, HF, FI
OPA	[3]–[5]	R&D	Probabilistic	Probabilistic	Monte Carlo	Generic model used	AC/DC	OL, EG
Practice	[6]	R&D	Probabilistic	Probabilistic	Enumeration	Specific state needed	AC	OL, HF, VV, FI
PCM	[7]–[9]	⊙	Deterministic	Deterministic	Enumeration	Specific state needed	AC	OL, VV, VI
TRANSMISSION 2000	[10]	⊙	Probabilistic	Deterministic	Enumeration	Specific state needed	AC	OL, VV
PSS/E	[11]	⊙	Probabilistic	Deterministic	Enumeration	Specific state needed	AC	OL, VI
TransCare	[12]	⊙	Deterministic	Deterministic	Enumeration	Specific state needed	AC	OL, VV, VI

⊙=Commercial, OL=Line Overloads, HF=Hidden Failures, VV=Voltage Violations, VI=Voltage Instability, FI=Frequency Instability, EG=Evolving Grid

of components, i.e., failure rates and sometimes also repair rates. The computation of the likelihood of multiple initiating events can differ from one methodology to another (e.g., PSS/E and Manchester model employ different equations). Moreover, the simulation of outages during the cascading phase entails a need to define the conditions under which an element is disconnected. These conditions can be based on deterministic thresholds (e.g., an overloaded line is disconnected as soon as its current exceeds a specific threshold) or probability distributions (e.g., an overloaded line has a probability to be disconnected, and that probability depends on the overload).

### III. METRICS AND INDICATORS FOR BENCHMARKING

It is not practical to compare individual cascades simulated by different simulations with different modeling assumptions, because slight differences can lead to different cascading outcomes (this is also the case in the real power system). What can be compared in the simulated cascades is the overall form of distributions of quantities. Every simulation produces many samples of cascades and the distribution of quantities over these samples can be easily obtained. This distribution corresponds to a probability distribution of the quantity in probabilistic simulations and the frequency distribution of the quantity in deterministic simulations. As described in the previous section, the cascade samples arise from running the simulation with suitable sampling from the initial power system state (if the analysis is not performed for a unique state), the initiating contingencies, or the following events (i.e., progression of the cascade).

For analysis purposes, cascades that only have an initial outage and then no further outages, or short cascades that do not shed load are included in the analysis. These small cascades are useful possible precursors to blackouts, have a successful outcome, and need to be included in the analysis to give a fair account of the power system performance.

The load shed is one important measure of the impact of a cascading outage on society. The expected load shed could thus be an important metric to benchmark the methodologies. However, the actual economic impact is not purely proportional to the load shed, i.e. the Value of Lost Load is not constant. The economic impact depends in particular on the duration of the power outage and the frequencies of the outages. Also, the expected load shed is not sufficiently informative and must be augmented by the distribution of load shed, i.e. the frequencies of the various sizes of blackouts,

given that a blackout occurred. The cascade size can also be measured by the number of lines outaged. This does not directly measure any societal consequence, but it includes the cascades that do not shed load, and these cascades can be thought of as blackout precursors.

In several methodologies (but not all of them), cascades of outages can be grouped into generations or tiers; in simulations this often corresponds to fast actions or an outer loop of calculations. Then in each cascade “parent” outages produce “child” outages in the next generation, and the children may become parents themselves to produce a further generation, and so on. The average propagation is the average number of children per parent and is calculated from the data simply by dividing the total number of children in all the cascades by the total number of parents. The average propagation quantifies how much the cascades grow beyond the initial outages.

Because investment in cascading mitigation should be driven by risk (probability  $\times$  cost), we combine the expression for EENS in terms of real power load shed in [13] with a rough estimate of blackout cost of \$1000 for 1 MWh to approximate direct blackout costs in US dollars as  $C = 500(\text{load shed})^{1.5}$  \$ (this only approximates direct costs, and neglects reputational, regulatory, and social costs).

One use for cascading simulations is to identify the lines that are critical for cascading. There are several interesting definitions of critical for cascading, including participating often in the initiating outages, participating often in initiating outages that lead to substantial cascading, or participating often in cascading propagation. These definitions correspond to the different mitigation objectives of minimizing all initial outages, minimizing initial outages that lead to substantial cascading, and minimizing the propagation of cascades after they initiate. The way that cascades are generated affects the interpretation of the critical lines. For example, instead of being driven by a contingency list or samples of combinations of lines out, some simulations and the historical data are driven by weather events and other hazards, and this yields the critical lines of the power system stressed by those hazards. We give the definitions and results for several simulations to foster comparison and discussion of these ranking methods.

## IV. NUMERICAL RESULTS

### A. Benchmarking system

The QSS methods are tested on the standard RTS-96 3-area system model [14], shown in Figure 2. The RTS-96 3-

area system has 73 buses and 120 branches. The total load in the system is 8550 MW. Compared to the initial model, each reactor of 100 MVAR at buses 106, 206 and 306 is split in two, 50 MVAR at each extremity of the cable. These reactors are considered to be automatically disconnected in case of the outage of the corresponding cable. The pre-contingency steady-state is based on a Preventive-Security-Constrained Optimal Power Flow, such that the system is  $N - 1$  secure<sup>1</sup>.

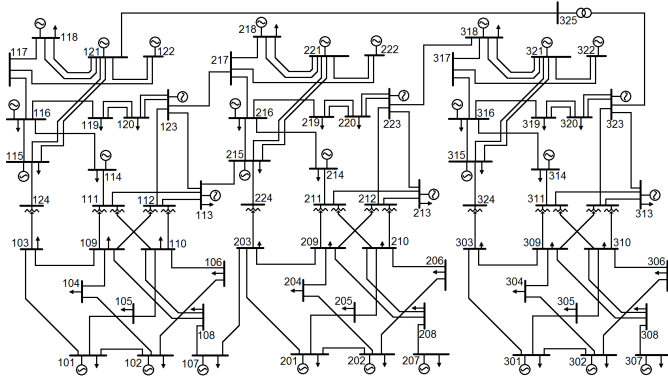

Fig. 2. RTS-96 3-area system.

### B. Specific simulation parameters

The benchmark includes all methodologies presented in Table I, and the OPA methodology is applied both using a DC and an AC OPF. For the Manchester model, 1 billion simulations and a hidden failure probability of 1% are used. For both the AC and the DC OPA models, the initial failure probability of each line is assumed to be 0.01, and a line is disconnected when its power flow is larger than 99% of its rating. The DC OPA model is run 1,000,000 times, while the AC OPA model is run 30,000 times. In PRACTICE, the following parameters are adopted to model the behavior of protection systems: hidden failure probability of 1%, pick-up current of all overcurrent relays (for both lines and transformers) of 1.2 pu, standard deviation for the probability distribution of the overcurrent protection relay of 0.02. For the PCM model, Transmission 2000 and PSS/E,  $N - 1$  and  $N - 2$  contingencies are tested. The following assumptions are used in the PCM model: lines and transformers are disconnected when the power flow goes over 125% of their rating, and loads and generators are disconnected when the voltage goes below 0.9 pu, or over 1.1 pu. For PSS/E, lines and transformers are disconnected when the power flow goes over their emergency rating. For TRANSMISSION 2000, the cascade analysis stops when the demand loss reaches 500 MW. For TransCARE, the following threshold values are used: lines and transformers are disconnected when the power flow goes over 125% of their rating, and loads and generators are disconnected when the voltage goes below 0.9 pu.

### C. Historical data

Although there is no historical data corresponding to the RTS-96 system model, it is still useful to see examples of real

forms of historical data to help guide the simulations towards the ultimate goal of a validated reality. For distribution of load shed, statistics are taken from the NERC data for the North American WECC region [13]. For distribution of line outages, statistics are taken from BPA data, processed into cascades and generations with the methods of [15]. The average propagation is 0.28.

### D. Summary and discussion of results

As explained in section III, the quantities compared in the benchmarking are the risk (in terms of expected demand loss), the probability distribution of the demand loss, the distribution of lines outaged in each cascade, the average propagation and the top 10 critical facilities. The simulations vary in the way they generate initial outages, so this information is also given to aid comparison. For distributions, historical data are also given. However, in comparing the results of the simulations of RTS system with the historical data, it should be recalled that the historical data is observed in one real system, and is only included as a guide to what can happen in reality. Only the general form of the historical data is informative in this context.

Table II indicates the risk in terms of expected demand loss. Only methodologies considering initiating events in a probabilistic way can lead to an estimation of expected demand loss. Although the order of magnitude of the expected demand loss is the same for the different methodologies, there are significant differences: a factor of 4 appears between PSS/E and Practice. Note that initiating events considered in PSS/E are limited to N-1 and N-2 contingencies, so it appears logical to obtain an underestimation of the risk.

TABLE II  
AVERAGE RISK

Methodology	Expected demand loss (MW/year)
Manchester	189.4
DC OPA	130.7
Practice	250.5
PSS/E	79.8

To complement Table II, Figure 3 shows the distribution of load shed in the form of the survival function of data from all the methods. The survival function is equivalent to  $1 -$  (cumulative distribution function) and shows the probability that the demand loss is larger than a given value, given that demand loss occurred in the system. For all methodologies, the limit of this probability is thus 1 when the demand loss approaches 0. The way in which the survival function decreases as blackout size increases shows the decreasing frequencies of blackouts as their size increases. Figure 3 is a log-log plot so that the smaller probabilities of the larger blackouts can be seen. Indeed, the historical blackout data in Figure 3 declines roughly linearly on a log-log plot. This is called a “heavy tail” and it implies that large blackouts are rarer than smaller blackouts, but not so rare that their risk is smaller. Indeed the historical data shows that the risk of large blackouts exceeds the risk of medium size blackouts

<sup>1</sup>Details: [http://homepages.ulb.ac.be/~phenneau/CFWG\\_Benchmark.html](http://homepages.ulb.ac.be/~phenneau/CFWG_Benchmark.html)

[13]. Therefore any risk-based mitigation should aim to jointly reduce the probability and impact of both large and small blackouts, and it is the purpose of Figure 3 to allow the predicted frequencies of all blackout sizes to be compared. Up to approximately 1% of the total load, all methodologies estimate similar survival functions. On the other hand, the benchmarked methodologies lead to very different estimation of the total blackout probability. The two extreme cases are PSS/E and DC OPA. On one hand, PSS/E stops the analysis in lack of power flow convergence and the post-processing performed in this paper assumes then a complete blackout. Because the system is initially in  $N - 1$  security, demand loss appears only for  $N - 2$  contingencies. As several  $N - 2$  contingencies are assumed to lead to a complete blackout, the conditional probability of having a complete blackout, given that demand loss occurred in the system, is very high. On the other hand, in the DC OPA methodology, the system does not have voltage stability issue, and loads can always be supplied by local generators. As several loads are connected to a bus with a generator, the probability to have a complete blackout is zero. While an assumption similar to that used for PSS/E might have been made for the TRANSMISSION 2000 results, for this methodology any results beyond a user defined load loss are considered speculative and therefore results have not been included. Nevertheless, the methodology provides ranking of cascades by excluding sequences that are unlikely to result in uncontrolled widespread cascading

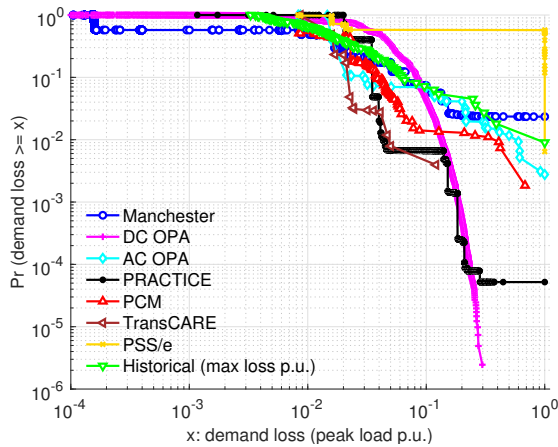

Fig. 3. Distribution of load shed

The distribution of the number of lines outaged in the cascading data is shown as a survival function in Figure 4. It shows the probability that the total number of lines outaged is larger than a given value, given that at least one line outage occurred in the system. For all methodologies, this probability is thus 1 when the number of lines outaged is 1. This is however not the case for the historical data, because they are multiplied by the ratio of the number of lines in the RTS by the number of lines in the BPA system. Again, the log-log plot helps to show the frequency of the larger cascades that are likely to be more consequential. Because the Manchester model and PRACTICE are using the same way to estimate the probability of  $N - 2$  contingencies, and

because the power system is initially  $N - 1$  secure (i.e. a single contingency cannot entail a cascading outage), they lead to the same probability to have at least 2 lines outaged. They follow then similar patterns, showing a knee at 7 outaged lines and two plateaus with different probability levels ( $10^{-5}$  and  $10^{-7}$  respectively for Manchester and PRACTICE models). A similar but smaller plateau can be observed in the AC OPA results. Similarly to the distribution of load shed, the various methodologies benchmarked exhibit quite different patterns.

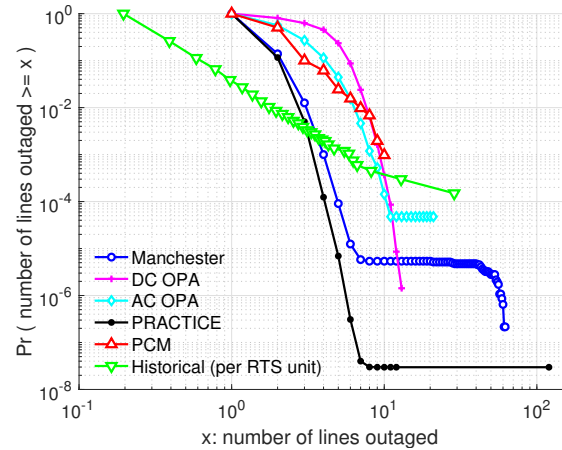

Fig. 4. Distribution of number of lines outaged

The historical data for load shed and number of lines outaged shows linear behavior on the log-log plots, which indicates a heavy tailed distribution. This form of behavior is also shown in some range of values by some of the simulations. The comparison is limited not only by the historical data being collected from systems different than the RTS, but also particularly by the larger size of these systems (WECC for load shed and 614 lines for line outages). The small size of the RTS could limit the cascading characteristics observed, and future benchmarking with larger systems is indicated.

Tables III and IV compare the top 5 critical components involved in initial outages, and the critical components involved in subsequent outages, respectively. PSS/E has been left out of the second table, because it does not provide details on components tripped within each cascading outage simulation. Although some lines appear critical for several methodologies (e.g. line between buses 314 and 316), most of them are identified as critical only by one or two methodologies.

## V. DISCUSSION ON PRACTICAL IMPLICATIONS

Both the planning and the operation of power systems can be improved (e.g. by investments in transmission facilities and modifications of the dispatch) based on an estimation of the risk of cascading outage. Although the assessment of the risk of cascading outage is not yet a planning and operation standard procedure all over the world, it is already required by the NERC reliability standard TPL-001-4 “Transmission System Planning Performance Requirements” as part of the planning process in North America. Furthermore, pilot projects to integrate such an assessment in planning and operation processes are emerging in various regions.

TABLE III  
RANK OF TOP 5 CRITICAL COMPONENTS INVOLVED IN INITIAL OUTAGES, FOR EACH METHODOLOGY

Line	107-108	307-308	207-208	308-309	208-209	309-324	208-324	303-210	315-121	206-121	115-320	319-221	215-123	220-223	316-317	314-316	306-310	208-210	308-310	106-110	116-119	214-216	115-116	215-216	312-323	313-323	213-223	116-117	
Manchester				3				1																	4	5		2	
DC OPA	3	2	1												5	4													
AC OPA									5	4	3	2	1																
PRACTICE			5	4				3																					
PCM															2								4			1	3	5	
Tr. 2000																						1	2	3	4				
PSS/E						4	3								2	1					4								
Transcare	3	2				5	4								1														

TABLE IV  
RANK OF TOP 5 CRITICAL COMPONENTS INVOLVED IN SUBSEQUENT OUTAGES, FOR EACH METHODOLOGY

Line	207-208	307-308	107-108	308-309	208-209	115-121	315-321	303-309	301-303	101-103	206-210	106-110	306-310	107-203	318-223	314-316	116-117	215-221	312-323	313-323	103-109	
Manchester						1	2									4	3	5				
DC OPA	2	1	3												5	4						
AC OPA	5	4									3	2	1									
PRACTICE				5	3			4	2	1												
PCM								4								3				2	1	5

For both planning and operation applications, an estimation of the average risk is not sufficient: critical elements have to be identified such that actions to address the weak points can be taken. Results show that the estimation of the average risk is of the same order of magnitude for the different methodologies, but that a large variation can be observed in distributions and in critical elements. It implies that the conclusions about planning and operation actions to take strongly rely on the specific cascading outage analysis methodology used. Moreover, there is variation in how the critical elements are defined. This lack of robustness can be a major barrier hampering the use of assessment of the risk of cascading outage in planning and operation processes. Additional R&D work is thus needed to narrow down the range of results obtained from the different QSS cascading outage methodologies, such that robust recommendations can emerge from such analyses. The use of more detailed models considering the power system dynamics might be needed to achieve that goal.

## VI. CONCLUSIONS

Although various QSS cascading outage analysis methodologies exist, they have never been benchmarked on the same test system with the same initial conditions. This is precisely the purpose of this paper: to benchmark the performance of several widely-used methodologies on the RTS-96. Results show common trends but also discrepancies between methodologies. It implies that there is not yet a standardized way to analyze the risk of cascading outage in power systems, and that the specific tool used by a power system engineer can impact the recommendations. The benchmarking is useful in focusing the necessary discussion on detailed assumptions for modeling, sampling the cascading possibilities, setting parameters, computing the risk, and selecting critical elements for upgrade.

Further R&D work is thus needed to align the methodologies.

## REFERENCES

- [1] J. Bialek et al., "Benchmarking and validation of cascading failure analysis tools," *IEEE Trans. Power Systems*, vol. 31, no. 6, pp. 4887–4900, Nov. 2016.
- [2] M. A. Rios, D. S. Kirschen, D. Jayaweera, D. P. Nedic, and R. N. Allan, "Value of security: modeling time-dependent phenomena and weather conditions," *IEEE Trans. Power Syst.*, vol. 17, no. 3, pp. 543–548, 2002.
- [3] I. Dobson, B. Carreras, V. Lynch, and D. Newman, "An initial model of complex dynamics in electric power system blackouts," in *34th Hawaii Intl. Conf. System Sciences*, 2001, pp. 710–718.
- [4] S. Mei, Y. Adana, X. Weng, and A. Xue, "Blackout model based on OPF and its self-organized criticality," in *2006 Chinese Control Conference*, Aug. 2006, pp. 1673–1678.
- [5] S. Mei, Y. Ni, G. Wang, and S. Wu, "A study of self-organized criticality of power system under cascading failures based on AC-OPF with voltage stability margin," *IEEE Trans. Power Syst.*, vol. 23, no. 4, pp. 1719–1726, Nov. 2008.
- [6] E. Ciapessoni, D. Cirio, and A. Pitto, "Cascading simulation techniques in Europe: The PRACTICE experience," in *IEEE PES General Meeting*, 2013, pp. 20–25.
- [7] N. Bhatt et al., "Assessing vulnerability to cascading outages," in *IEEE/PES Power Systems Conf. & Exposition*, March 2009, pp. 1–9.
- [8] V&R Energy Systems Research, *Potential Cascading Modes (PCM) Program Manual*, 2012.
- [9] M. Papic and I. Dobson, "Comparing a transmission planning study of cascading with historical line outage data," in *Probabilistic Methods Applied to Power Systems*, Oct 2016, pp. 1–7.
- [10] S. S. Miller, "Extending traditional planning methods to evaluate the potential for cascading failures in electric power grids," in *IEEE PES General Meeting*. IEEE, 2008, pp. 1–7.
- [11] Siemens, *PSS®E 33.5 Program Application Guide - Volume 1*, 2013.
- [12] Electric Power Research Institute (EPRI), *TRELSS Application Manual: For Cascading Failure, Reliability and Deterministic Analysis*, 2003.
- [13] B. A. Carreras, D. E. Newman, and I. Dobson, "North American blackout time series statistics and implications for blackout risk," *IEEE Trans. Power Systems*, vol. 31, no. 6, pp. 4406–4414, 2016.
- [14] C. Grigg et al., "The IEEE reliability test system-1996," *IEEE Trans. Power Systems*, vol. 14, no. 3, pp. 1010–1020, 1999.
- [15] I. Dobson, "Estimating the propagation and extent of cascading line outages from utility data with a branching process," *IEEE Trans. Power Systems*, vol. 27, no. 4, pp. 2146–2155, 2012.